

Specifications and Options

Exhaust & Internal Supply – Model SCS

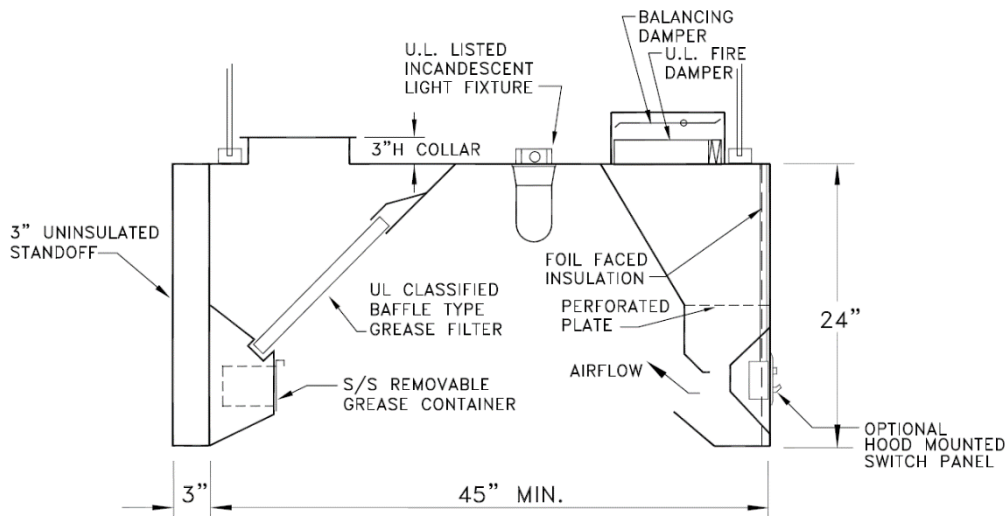

Hood Specifications:

-Material: Exposed hood areas constructed of 18 gauge type 304 stainless steel or 430 stainless steel with # 3 polish. Unexposed areas constructed of 18 gauge aluminized steel.

-Construction: Exterior shell of hood is continuously welded liquid tight per NFPA-96. All exposed joints and seams are polished to the original finish. Hood front is double shell construction for added hood front rigidity at all hood lengths.

-3" Rear Standoff: Non-insulated, factory installed at rear of hood provides 3" clearance to rear wall.

-Lights: U.L. Listed Incandescent type light fixtures located on 3' to 4' centers. Lights include shatterproof globes. Lights are pre-wired to junction box at top of hood.

-Filters: U.L. Classified heavy duty aluminum or stainless steel baffle type grease filters located in hood filter frame assembly. Filters are removable for cleaning.

-Grease Container: Concealed stainless steel removable grease container located in hood interior isolated from airstream.

-Hanger Brackets: Heavy steel 6" uni-strut hanger brackets at hood top with adjustable spring loaded rod coupling for 1/2" threaded hanger rod.

-Exhaust Duct Collar: 3" High Exhaust duct collar is factory installed in top of hood or shipped loose for field location. Duct collar contains perimeter welding flange for field welding of exhaust duct.

-Approvals: Hood is ETL Listed to conform to U.L. 710 standards. Hood is NSF Listed and built in strict accordance with the latest edition of National Fire Protection Association, NFPA-96

Hood Options:

-Material: Entire hood constructed of 18 gauge or 16 gauge stainless steel or aluminized steel.

-Lights: U.L. Listed Recessed fluorescent type or LED light fixtures available, double tube style in 3' or 4' lengths.

-Filters: U.L. Classified heavy duty stainless steel baffle type grease filters.

-Grease Extractors: All stainless steel construction high velocity grease extractor for up to 95% grease containment.

-Switch Panel: Hood mounted or provide loose for wall mounting. Panel may contain various light and fan switch combinations as required for system operation.

-3" Standoff: Insulated or Non-insulated, factory installed at hood ends or top as required for clearance to combustible or limited combustible surfaces.

-Ceiling Closure Panels: Closure panels to close off space between top of hood and ceiling as required can be factory installed to hood top or provided loose for field installation. **-Side Skirts:** Left or Right end skirt to close off end of hood as required.

-Wall Panels: S/S construction wall panels provided loose for field installation behind hood.

-Fire Control Cabinet: Fabricated onto left or right end of hood to contain fire system controls and electrical controls as required.

-Zero Clearance: Using approved methods of insulating a hood for Zero Clearance to combustibles for the front, top, and sides of the hood.

-Side Skirts: Left or Right end skirt to close off end of hood as required.

Specifications and Options

Exhaust & Internal Supply – Model SCS

CFM Information Data – Wall Mounted Application –Model SCS

Cooking Equipment	Max Surface Cooking Temp. Degrees F.	Exhaust CFM Per Foot of Hood Length	Supply CFM Thru Hood Front (% of Exhaust)	Supply CFM Introduced thru HVAC Unit
Light Cooking Load – <i>Ovens, Kettles, Ranges, Steam Equipment, Rotisseries</i>	250 to 400 Degrees F	230	70%	30%
Medium Cooking Load- <i>Griddles, Fryers, Braising Pans, Skillets, Salamanders, Upright Broilers</i>	400 Degrees F.	300	70%	30%
Heavy Cooking Load- <i>Electric or Gas Char-broilers, Wok Ranges</i>	600 Degrees F.	<u>Consult Factory</u>	<u>Consult Factory</u>	N/A

Hood Internal Static Pressure Losses:

Light Cooking Load: Exhaust = .55" (w/Baffle Type Filters), .75" (w/GRX High Velocity Extractors) Supply=.20"

Medium Cooking Load: Exhaust = .60" (w/Baffle Type Filters), .85" (w/GRX High Velocity Extractors) Supply=.25"

Heavy Cooking Load: Exhaust = .55" (w/Baffle Type Filters), .97" (w/GRX High Velocity Extractors) Supply=.32"