

# GENERAL NOTES

UNLESS OTHERWISE NOTED, ALL EXTERIOR SURFACES WILL BE 18 GA. GALVANIZED STEEL.

LISTED



# CURB SKIRT DETAIL

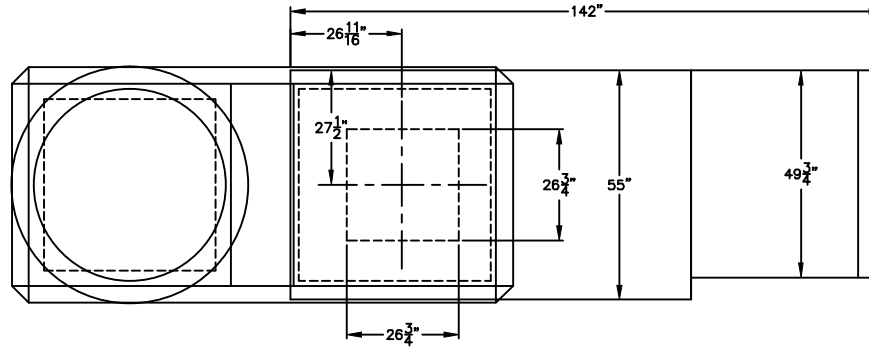
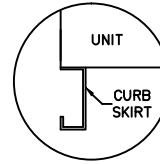

PLAN VIEW

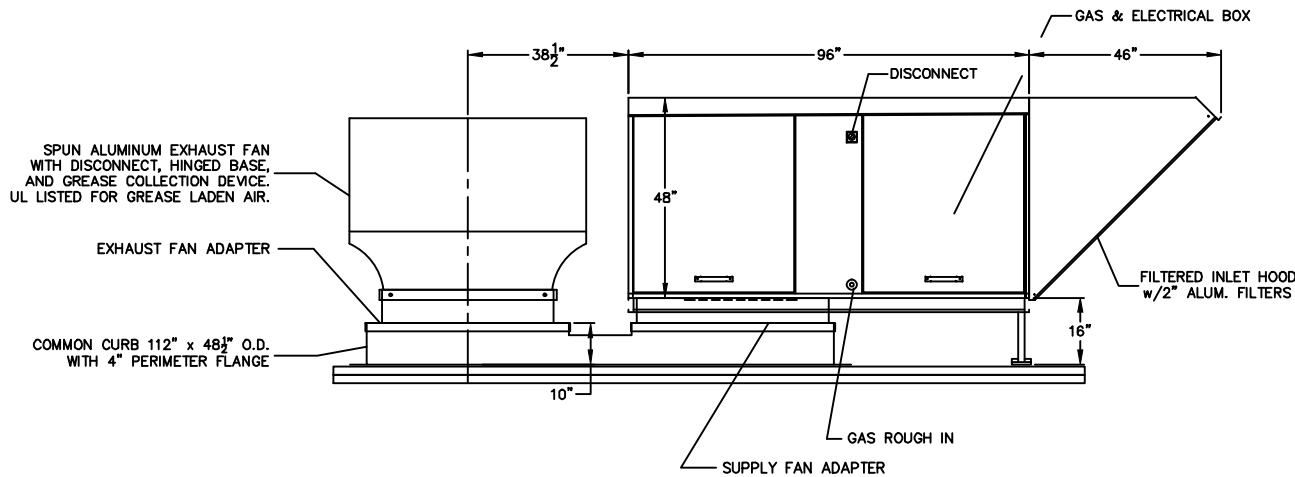

ELEVATION VIEW

PROJECT NAME:  
 REF. NO./DRAWING NO.:  
 DATE:

# ENGINEERING SPECIFICATIONS

MODEL: V5		
C.F.M.:	T.S.P.:	E.S.P.:
B.T.U. INPUT: 1,125,000	GAS LINE SIZE: 1"	
MIN. GAS PRESS.: 13" W.C.	MAX. GAS PRESS.: 28" W.C.	
H.P.:	VOLTAGE:	SERVICE AMPS.:
BLOWER MODEL # 920		

STANDARD FEATURES:

DIRECT GAS FIRED UNIT, NATURAL GAS
ETL CERTIFIED
GALVANIZED STEEL CASING; UNPAINTED
DOWN DISCHARGE CONFIGURATION
MAXITROL SERIES 14
REMOTE RESET OF FLAME SAFEGUARD
24V REMOTE CONTROL PANEL
ONE EXHAUST FAN STARTER
1" INTERNAL INSULATION
VIBRATION ISOLATORS
REMOVABLE BIRDSCREEN

OPTIONAL FEATURES:

NOTES:

SUPPLY AIR FLOW RANGE: 6,800 CFM TO 13,000 CFM

