

## GENERAL NOTES

UNLESS OTHERWISE NOTED, ALL EXTERIOR SURFACES WILL BE 18 GA. GALVANIZED OR ALUMINIZED STEEL.

INDIRECT SIZE	AIRFLOW RANGE	HEAT INPUT	HEAT OUTPUT
75	600-2,600	75 MBH	60 MBH

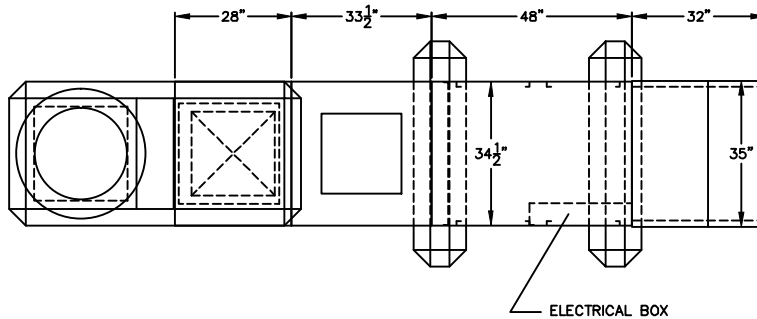

PLAN VIEW

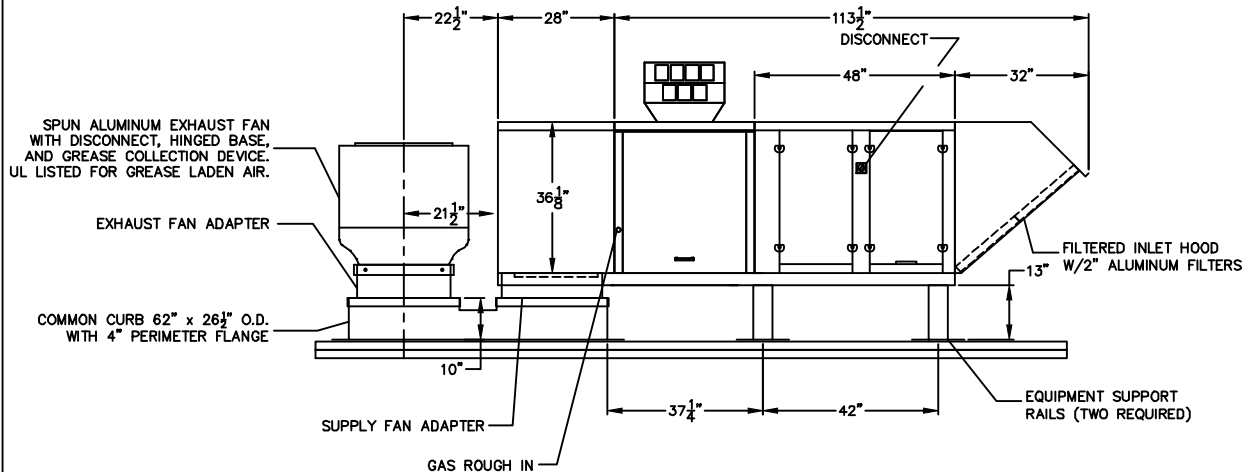

ELEVATION VIEW

PROJECT NAME:

REF. NO./DRAWING NO.:

DATE:

## ENGINEERING SPECIFICATIONS

MODEL: 11

C.F.M.: T.S.P.: E.S.P.:

B.T.U. INPUT: 75 MBH GAS LINE SIZE: 1/2"

MIN. GAS PRESSURE: 7" W.C. MAX. GAS PRESSURE: 14" W.C.

H.P.: VOLTAGE: SERVICE AMPS.:

BLOWER MODEL:

STANDARD FEATURES:

INDIRECT GAS FIRED UNIT, NATURAL GAS

ETL CERTIFIED DUCT FURNACE

STAINLESS STEEL HEAT EXCHANGER

80% MAXIMUM THERMAL EFFICIENCY

ALUMINIZED STEEL CASING; PAINTED SLATE GRAY

HORIZONTAL OR DOWN DISCHARGE CONFIGURATION

VIBRATION ISOLATORS

OPTIONAL FEATURES:

24V REMOTE CONTROL PANEL

EXHAUST FAN STARTER

MAXITROL SERIES 21 TEMPERATURE CONTROL

MOTORIZED INLET DAMPER

NOTES:

