

## Exhaust & Front Supply (Angled Perforated) Kitchen Hood - Model FSP-A / FSP-A-I Specifications and Options

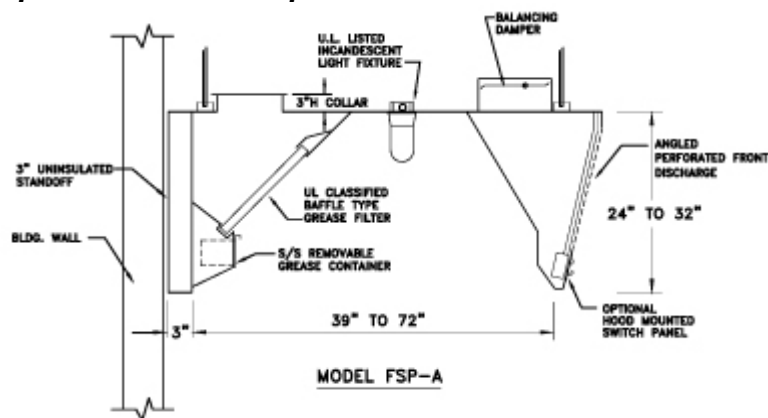

### **Hood Specifications:**

- Material:** Exposed hood areas constructed of 18 gauge type 304 stainless steel with # 3 polish. Unexposed areas constructed of 18 gauge aluminized steel.
- Construction:** Exterior shell of hood is continuously welded liquid tight per NFPA-96. All exposed joints and seams are polished to the original finish.
- 3" Rear Standoff:** Non-insulated, factory installed at rear of hood provides 3" clearance to rear wall.
- Lights:** U.L. Listed Incandescent type light fixtures located on 3' to 4' centers. Lights include shatterproof globes and are pre-wired to junction box at top of hood.
- Filters:** U.L. Classified heavy duty aluminum baffle type grease filters located in hood filter frame assembly. Filters are removable for cleaning.
- Grease Container:** Concealed stainless steel removable grease container located in hood interior isolated from airstream.
- Exhaust Duct Collar:** 3" High Exhaust duct collar is factory installed in top of hood. Duct collar contains perimeter welding flange for field welding of exhaust duct.
- Supply Duct Collar:** 8" High Supply duct collar is factory installed in top of hood. Duct collar includes adjustable damper for ease of airflow adjustment.
- Supply Plenum:** Integral supply plenum introduces supply air into kitchen through full length removable Angled Front perforated panels for even distribution of supply air.
- Approvals:** Hood is ETL Listed to conform to U.L. 710 standards. Hood is NSF Listed and built in strict accordance with the latest edition of the National Fire Protection Association, NFPA-96.

### **Hood Options:**

- Material:** Entire hood constructed of 18 gauge aluminized steel, with Mill Finish.
- Material:** Hood construction of 16 gauge stainless steel or aluminized steel.
- Lights:** U.L. Listed Recessed fluorescent type light fixtures, double tube style in 3' or 4' lengths.
- Filters:** U.L. Classified heavy duty stainless steel baffle type grease filters.
- Grease Extractors:** All stainless steel construction high velocity grease extractor for up to 95% grease containment.
- Switch Panel:** Hood mounted or provide loose for wall mounting. Panel may contain various light and fan switch combinations as required for system operation.
- 3" Standoff:** Insulated or Non-insulated, factory installed at hood ends or top as required for clearance to combustible or limited combustible surfaces.
- Ceiling Closure Panels:** Closure panels to close off space between top of hood and ceiling as required can be factory installed to hood top or provided loose for field installation.
- Side Skirts:** Left or Right end skirt to close off end of hood as required.
- Wall Panels:** S/S construction wall panels provided loose for field installation behind hood.
- Fire Control Cabinet:** Fabricated onto left or right end of hood to contain fire system controls and electrical controls as required.
- Fire System Piping:** Piping of hood for wet chemical fire suppression system. Exposed piping includes s/s or chrome sleeves.

**Exhaust & Front Supply (Angled Perforated) Hood - Model FSP-A / Model FSP-A-I  
CFM Information Data**

**CFM Information Data - Wall Mounted Application - Model FSP-A**

Cooking Equipment	Average Cooking Surface Temp. Degrees F.	Exhaust CFM Per Foot of Hood Length	Supply CFM Thru Hood Front (Percentage of Exhaust)	Supply CFM Introduced thru HVAC Unit
<b>Light Cooking Load -</b> Ovens, Kettles, Ranges, Steam Equipment, Rotisseries	250 to 400 Degrees F	152	up to 100%	NA
<b>Medium Cooking Load -</b> Griddles, Fryers, Braising Pans, Skillets, Salamanders, Upright Broilers	400 Degrees F	200	up to 100%	NA
<b>Heavy Cooking Load -</b> Electric or Gas Char-Broilers, Wok Ranges	600 Degrees F	275	up to 100%	NA

**Note: See Table 'D' for other CFM data and hood duct collar size information.**

**CFM Information Data - Back to Back Island Mounted Application - Model FSP-A-I**

Cooking Equipment	Average Cooking Surface Temp. Degrees F.	Exhaust CFM Per Foot of Hood Length	Supply CFM Thru Hood Front (Percentage of Exhaust)	Supply CFM Introduced thru HVAC Unit
<b>Light Cooking Load -</b> Ovens, Kettles, Ranges, Steam Equipment, Rotisseries	250 to 400 Degrees F	304 (152 Per Side)	up to 100%	NA
<b>Medium Cooking Load -</b> Griddles, Fryers, Braising Pans, Skillets, Salamanders, Upright Broilers	400 Degrees F	400 (200 Per Side)	up to 100%	NA
<b>Heavy Cooking Load -</b> Electric or Gas Char-Broilers, Wok Ranges	600 Degrees F	550 (275 Per Side)	up to 100%	NA

**Note: See Table 'J' for other CFM data and hood duct collar size information.**

**Hood Internal Static Pressure Losses-**

**Light Cooking Load :** Exhaust = .55" (w/ Baffle Type Filters) ; .75" (w/ GRX High Velocity Extractors)  
Supply = .20"

**Medium Cooking Load :** Exhaust = .60" (w/ Baffle Type Filters) ; .85" (w/ GRX High Velocity Extractors)  
Supply = .25"

**Heavy Cooking Load :** Exhaust = .72" (w/ Baffle Type Filters) ; .97" (w/ GRX High Velocity Extractors)  
Supply = .32"