

MODEL EC-FP2

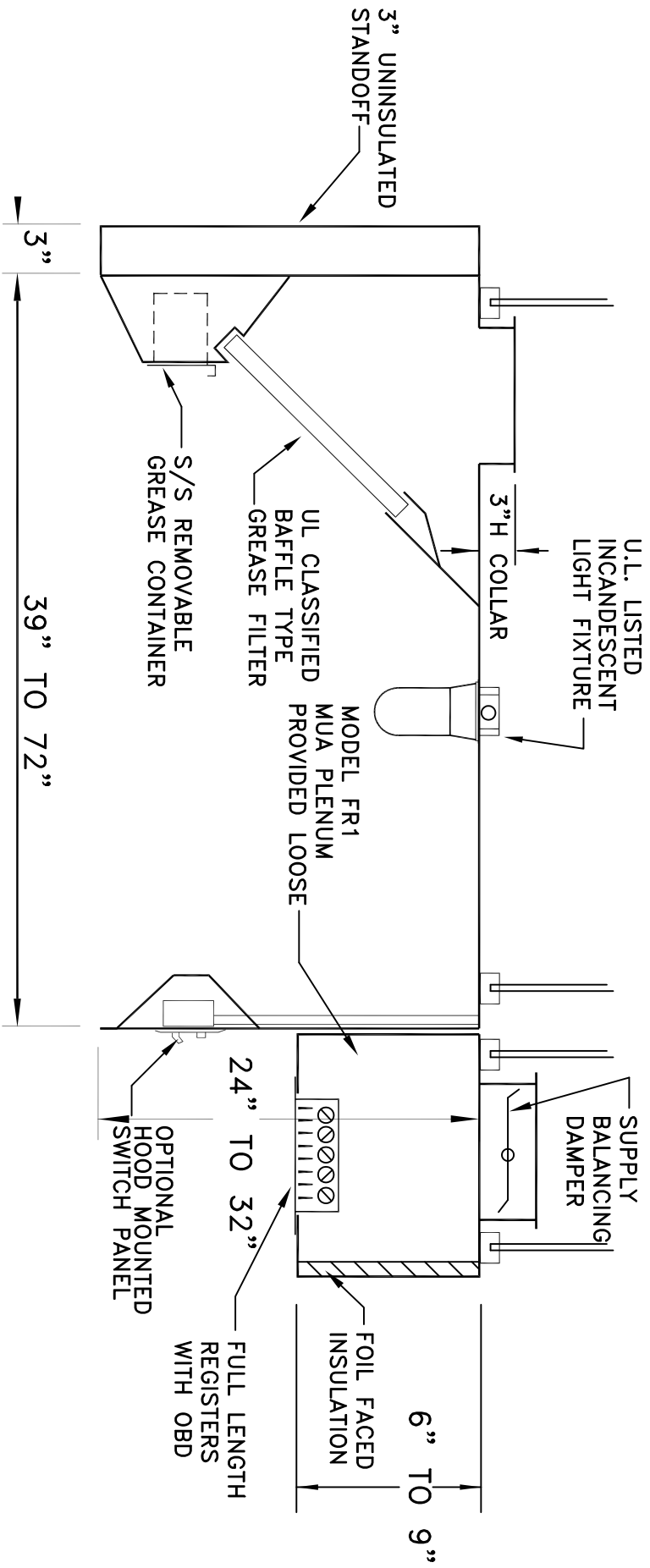

MODEL EC-FR1

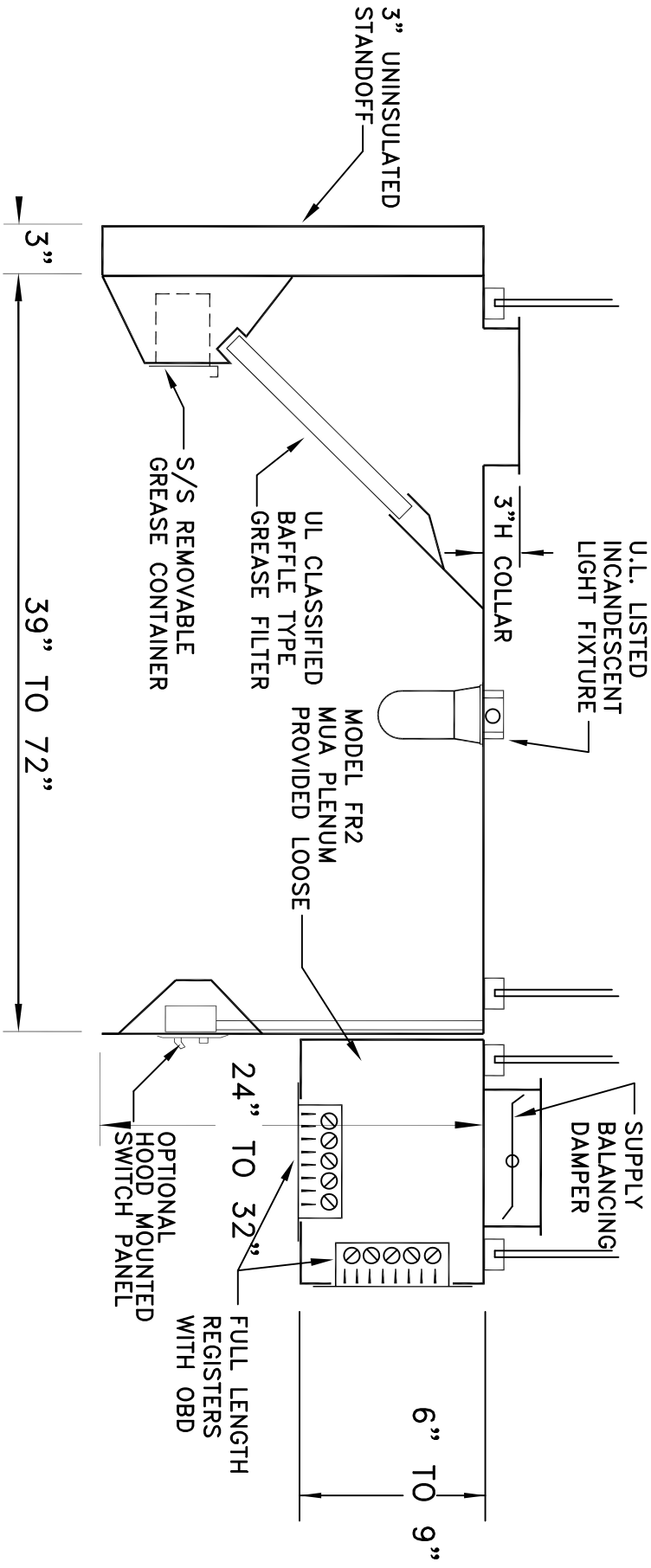

MODEL EC-FR2

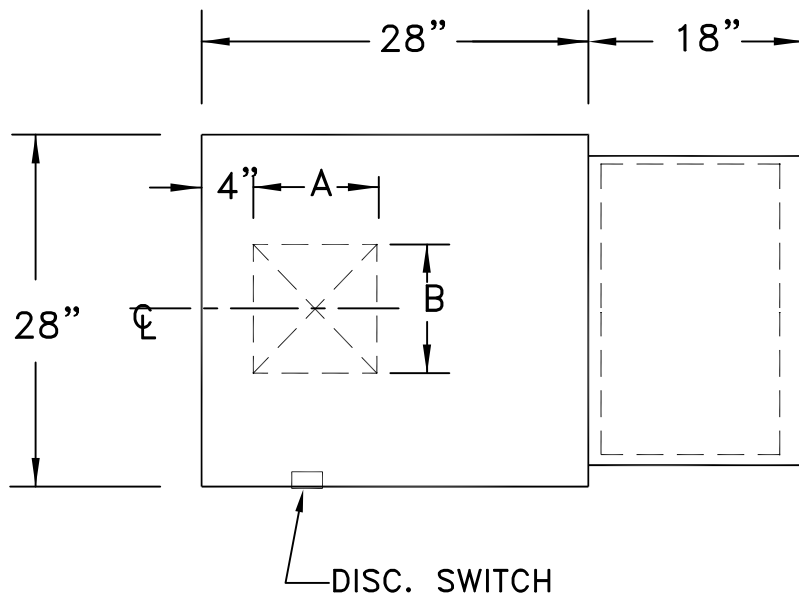
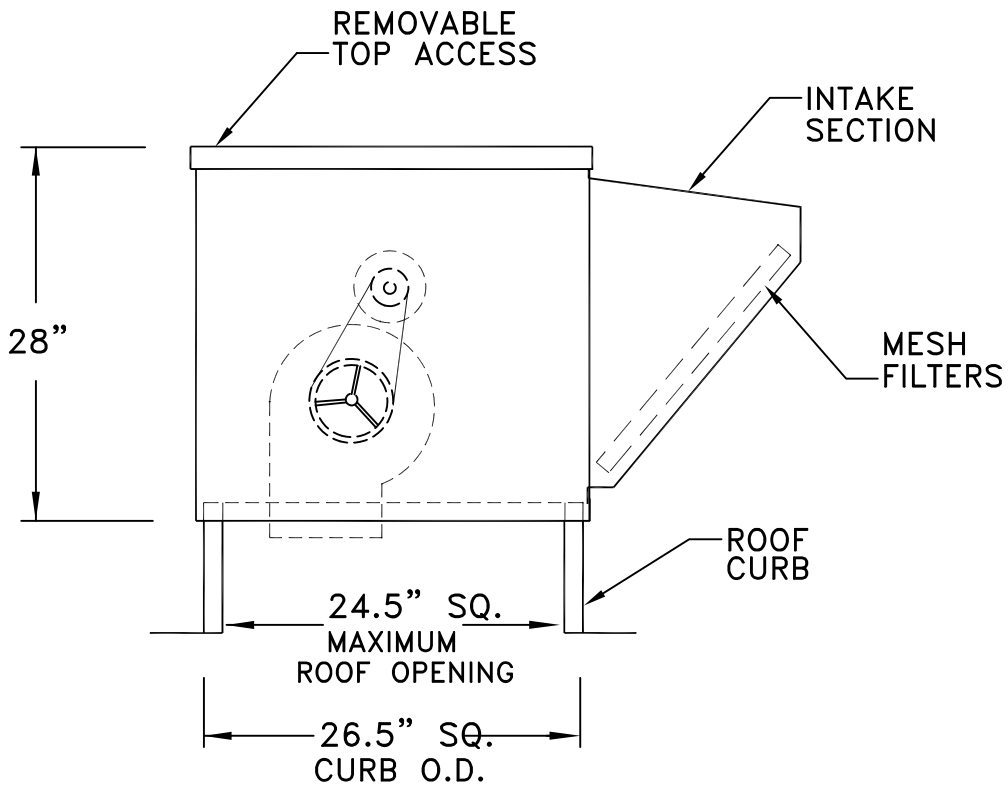

SAS10 ROOF MOUNT

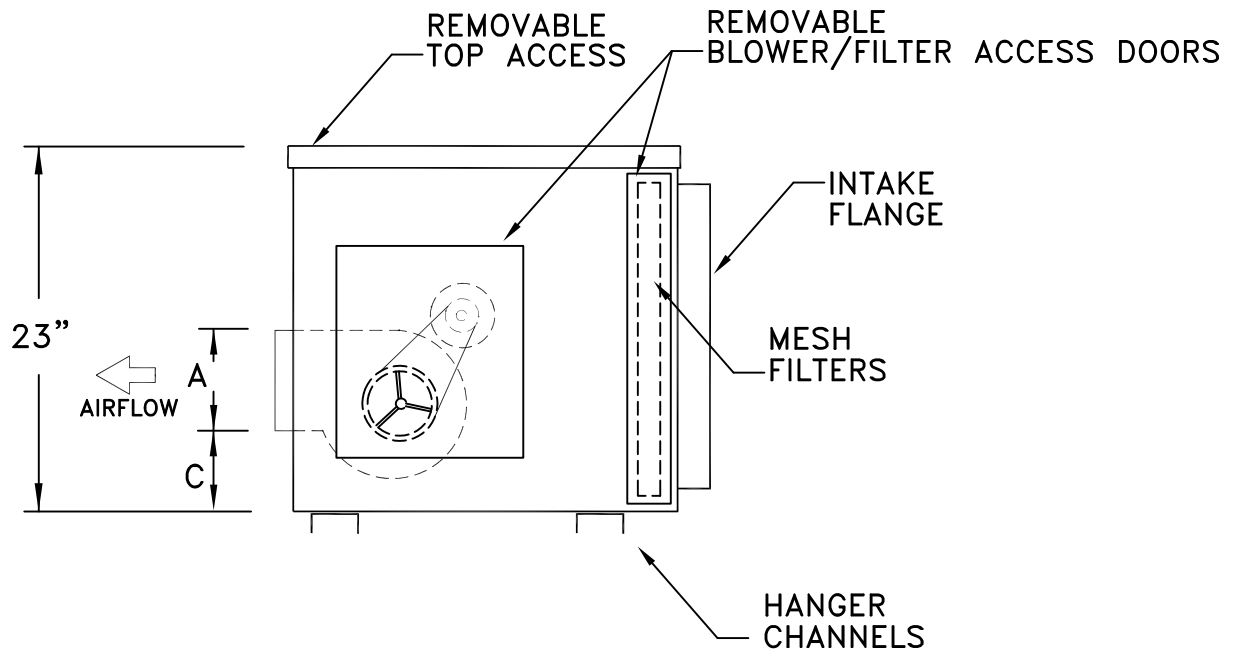

SECTION VIEW

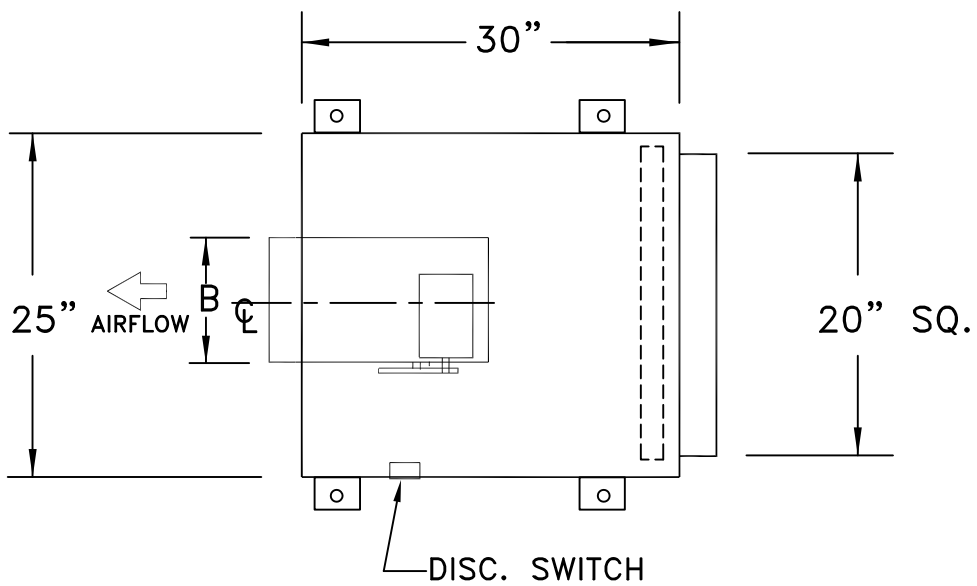

PLAN VIEW

SAS10-I

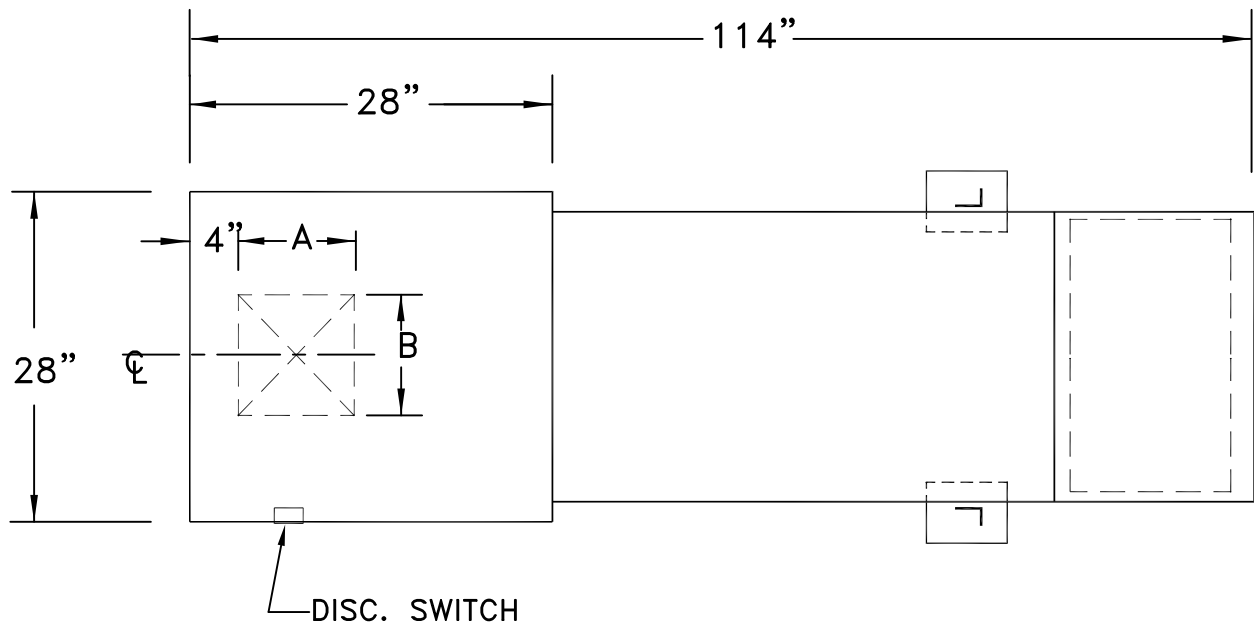
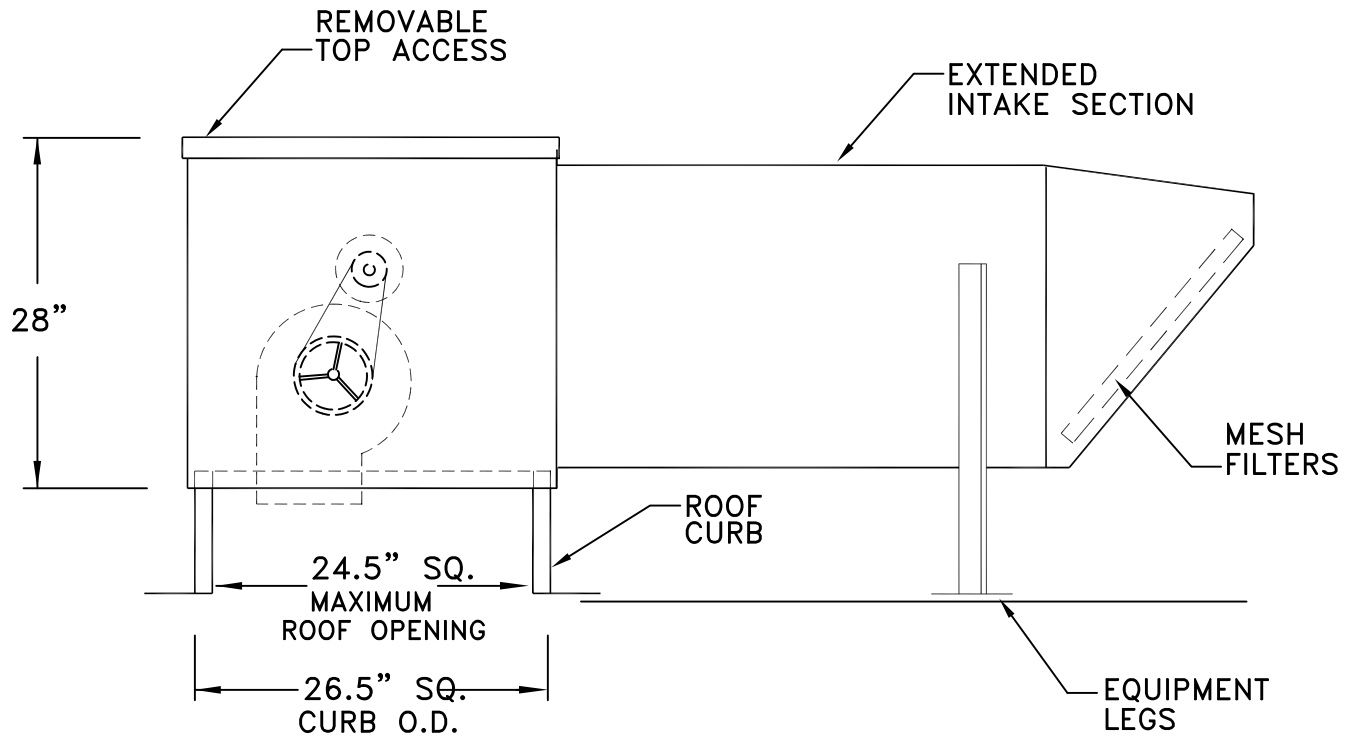

SAS10-T

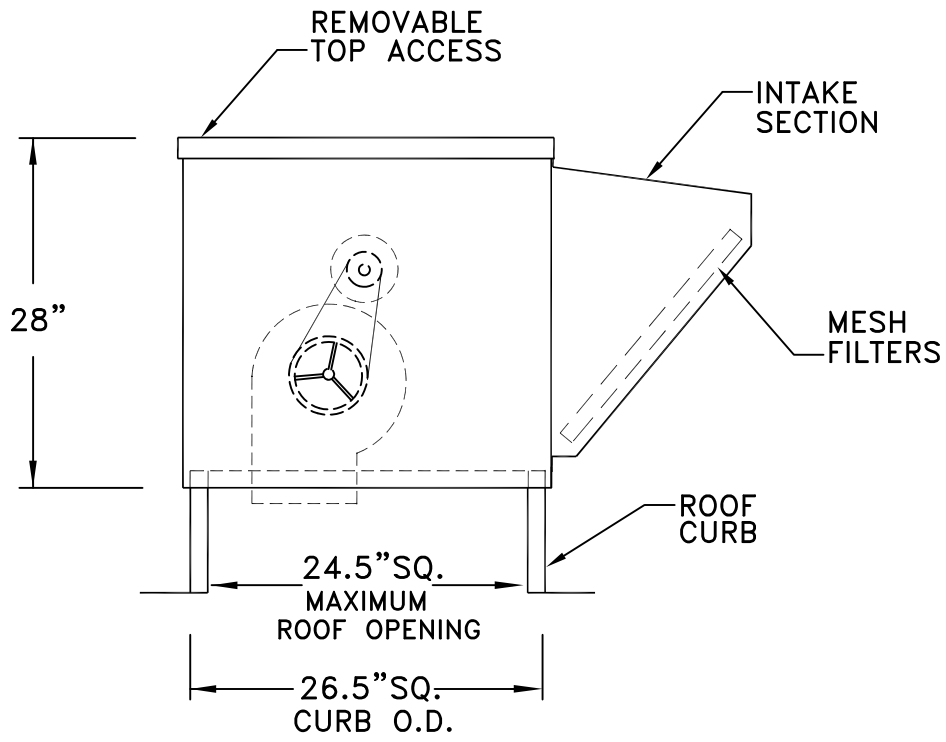

SECTION VIEW

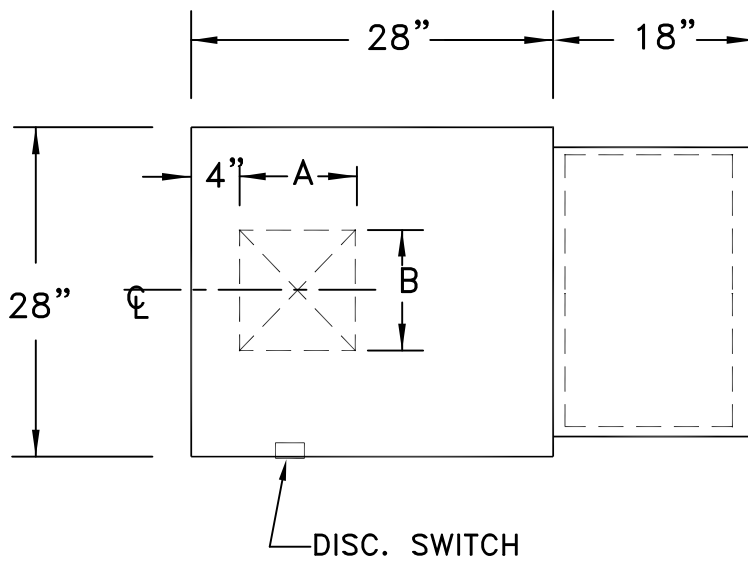

PLAN VIEW

SAS12 ROOF MOUNT

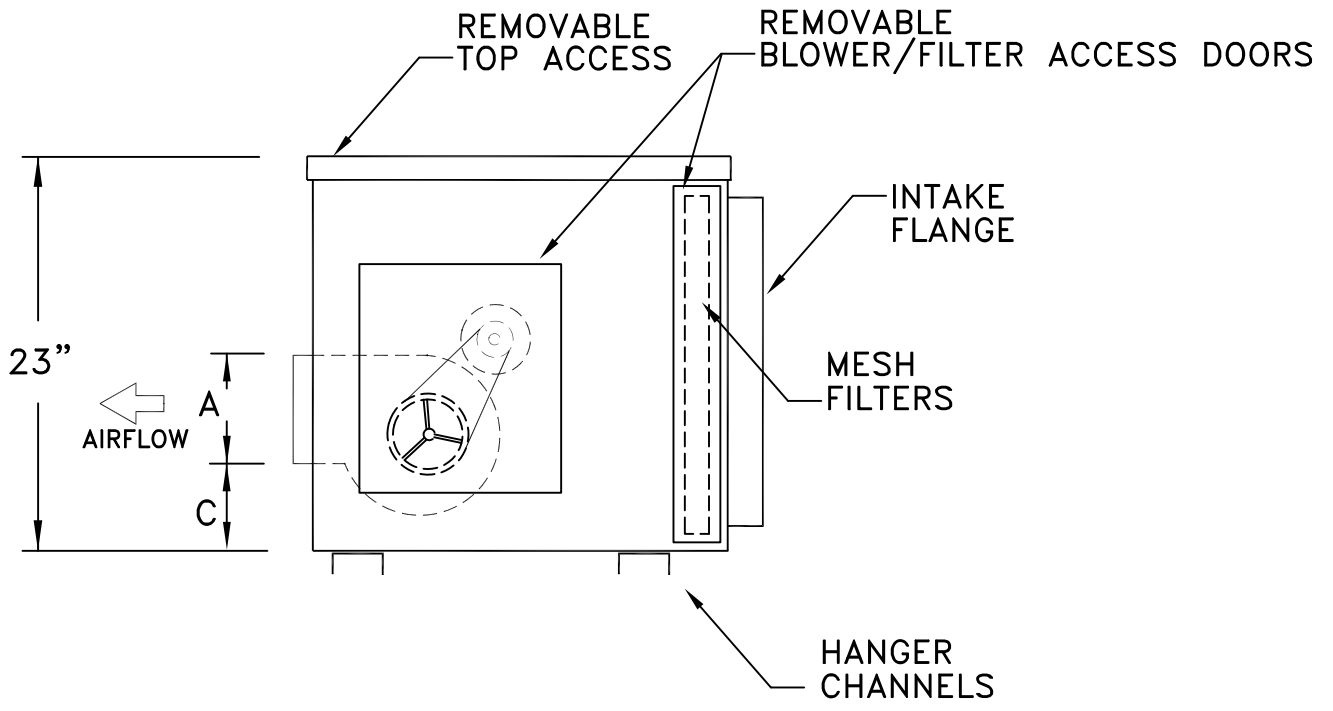

SECTION VIEW

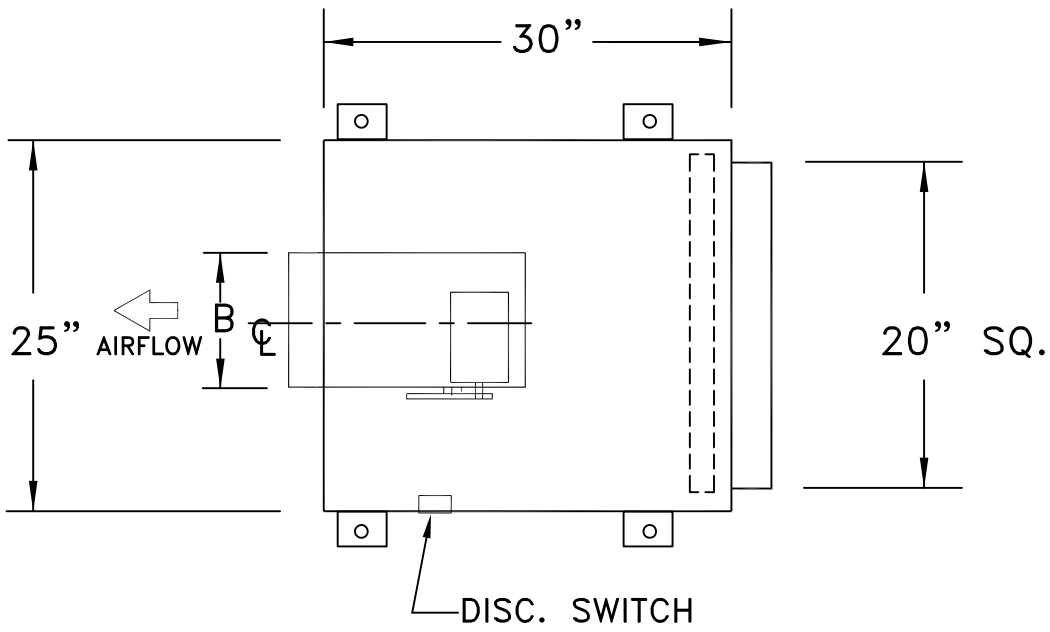

PLAN VIEW

SAS12-I



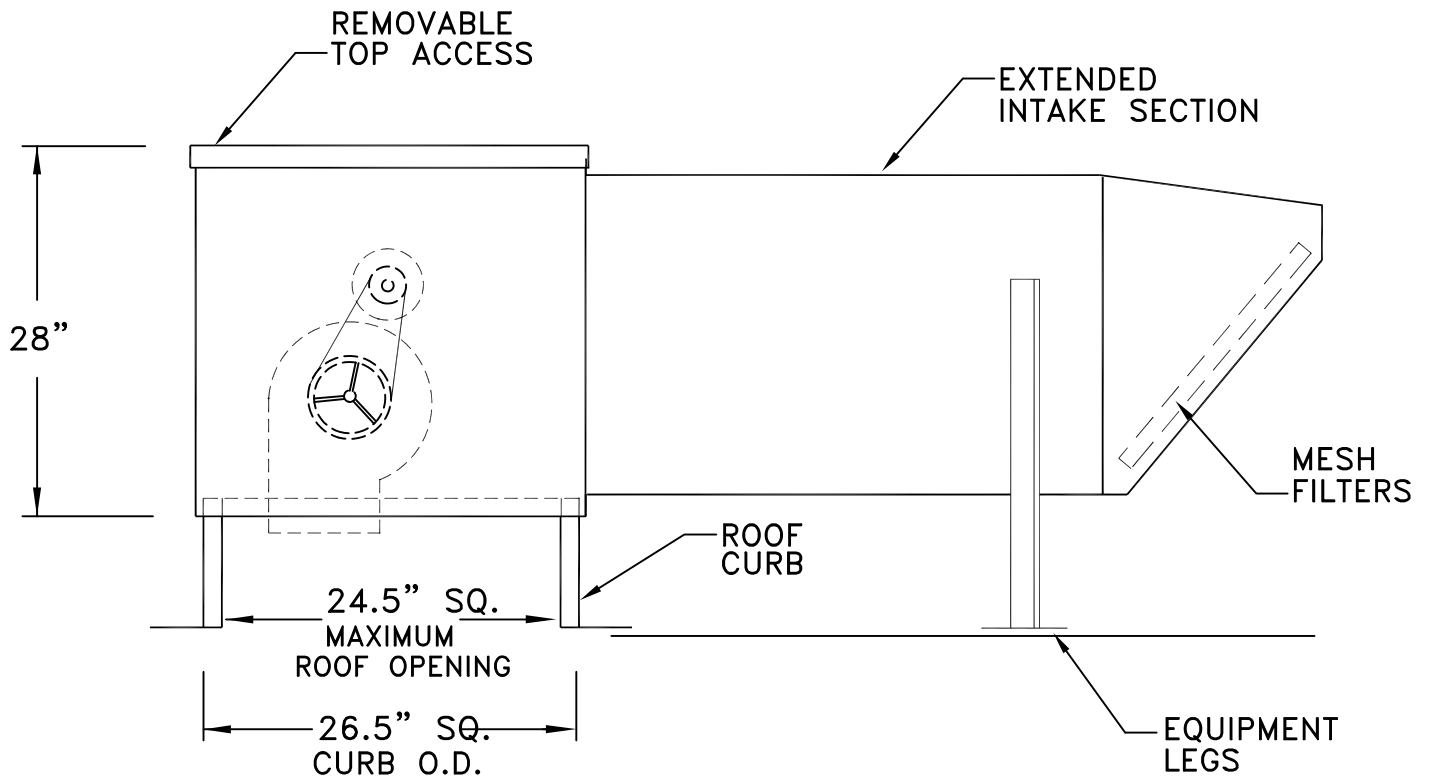

SECTION VIEW

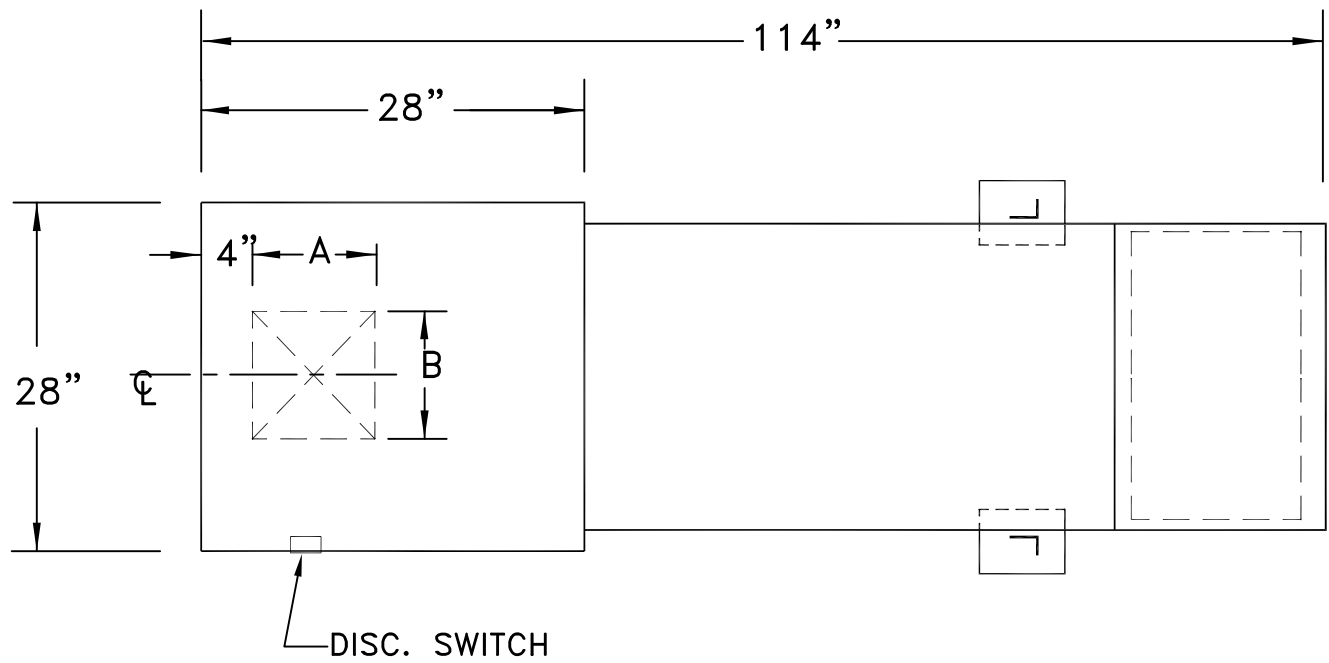

PLAN VIEW

SAS12-T

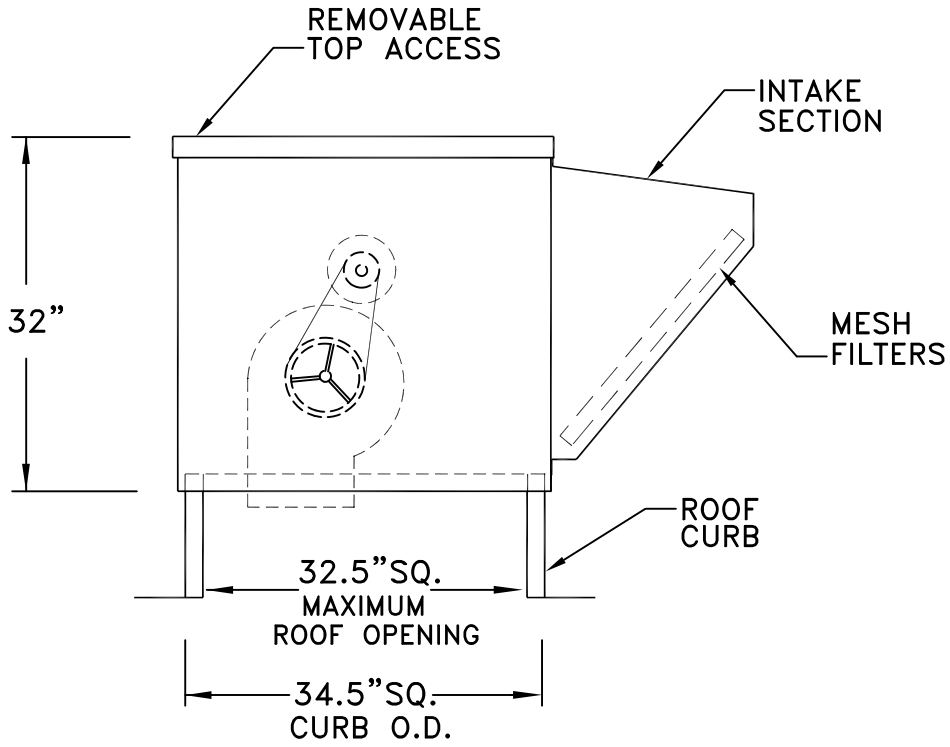

SECTION VIEW

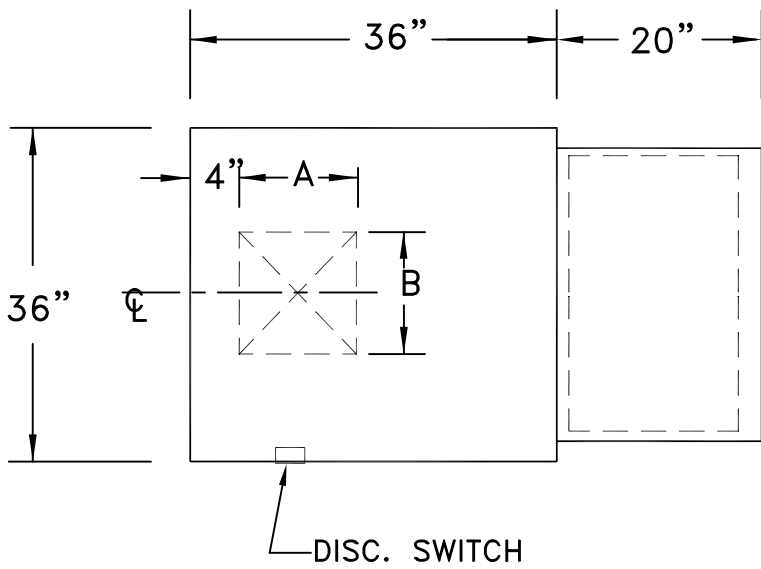

PLAN VIEW

SAS15 ROOF MOUNT

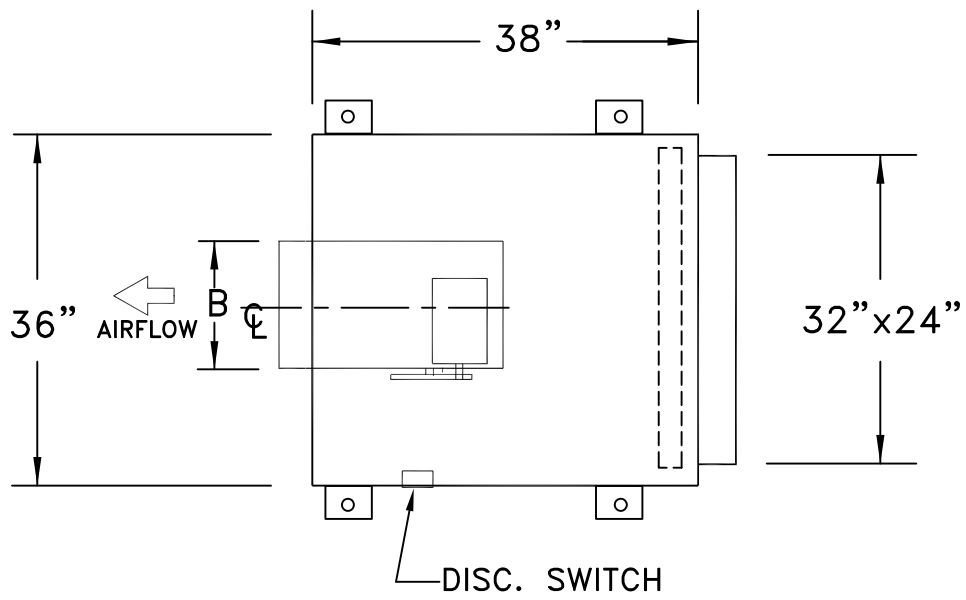
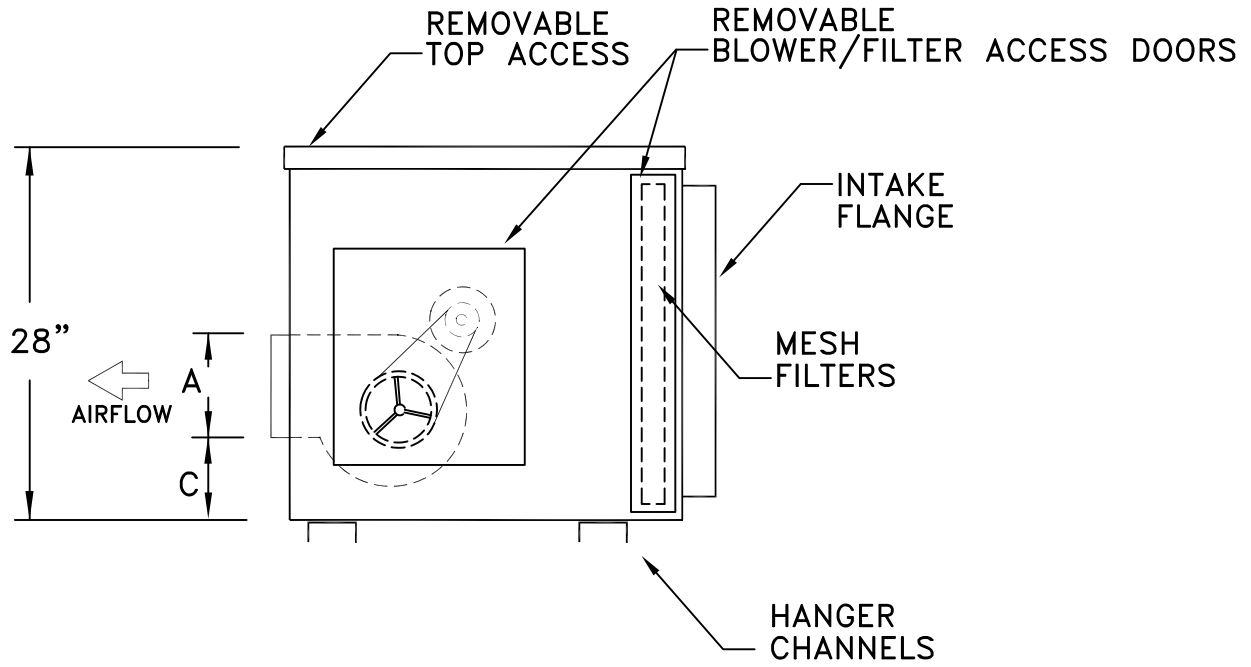

SAS15-1

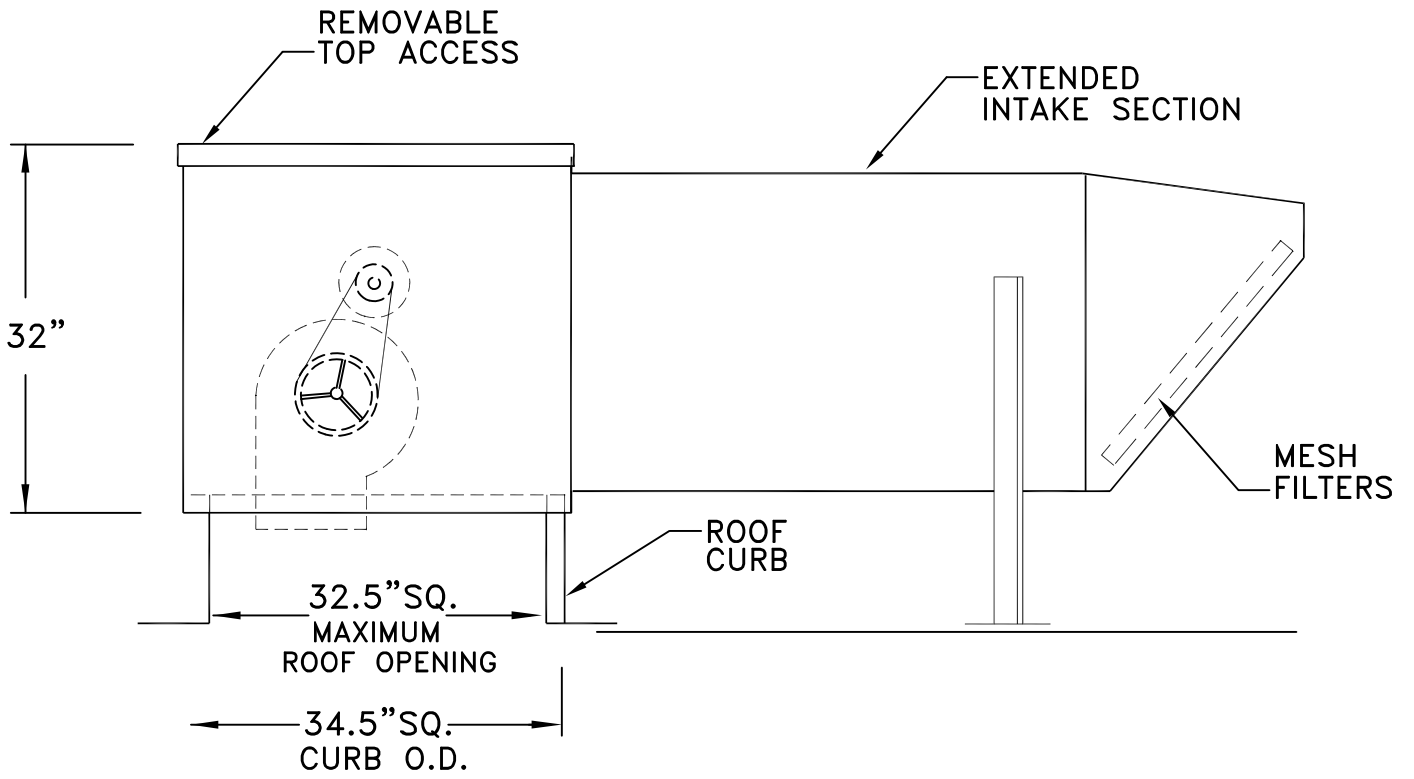

SECTION VIEW

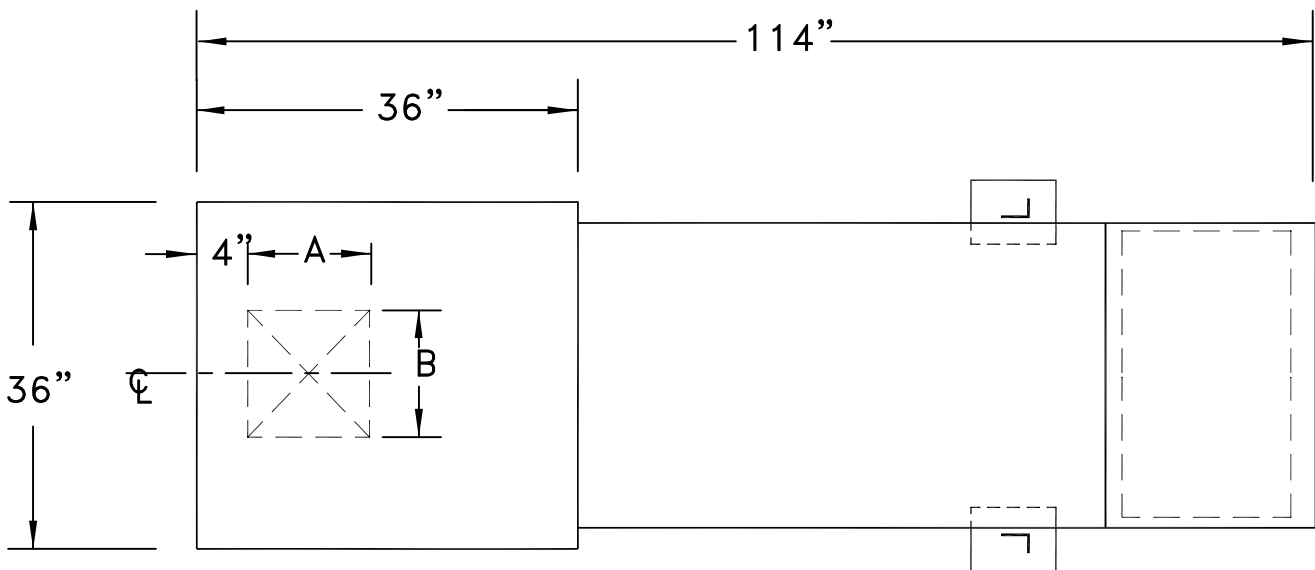

PLAN VIEW

SAS15-T

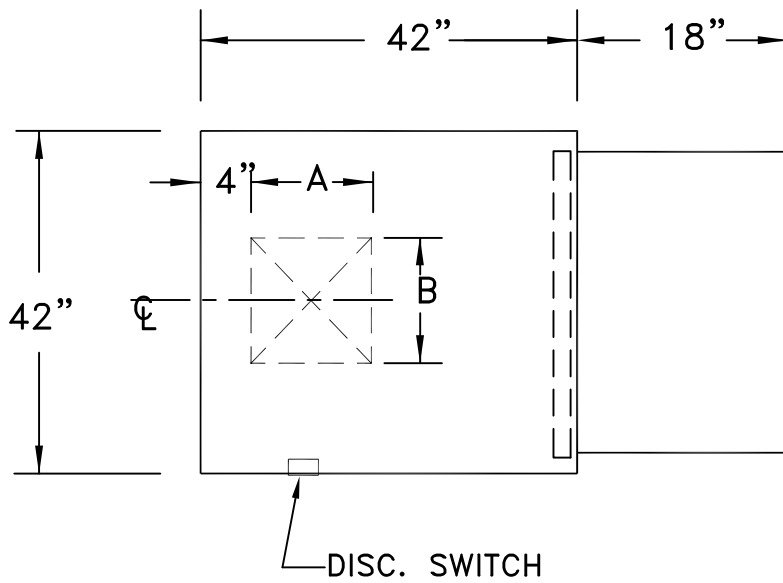
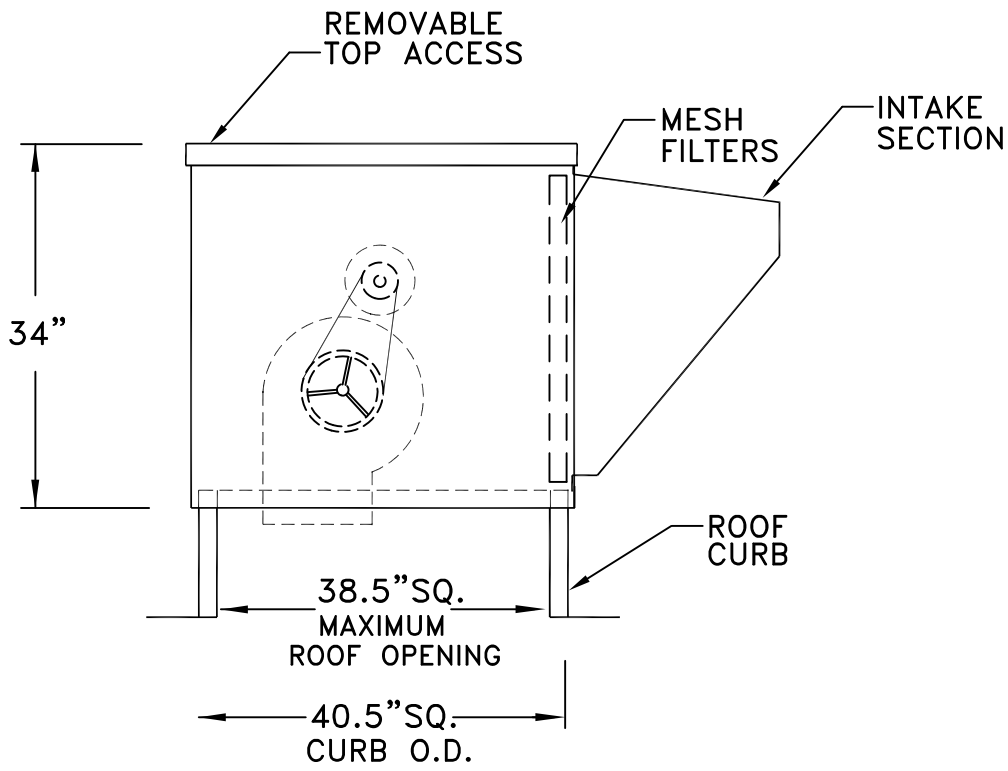

SAS18 ROOF MOUNT

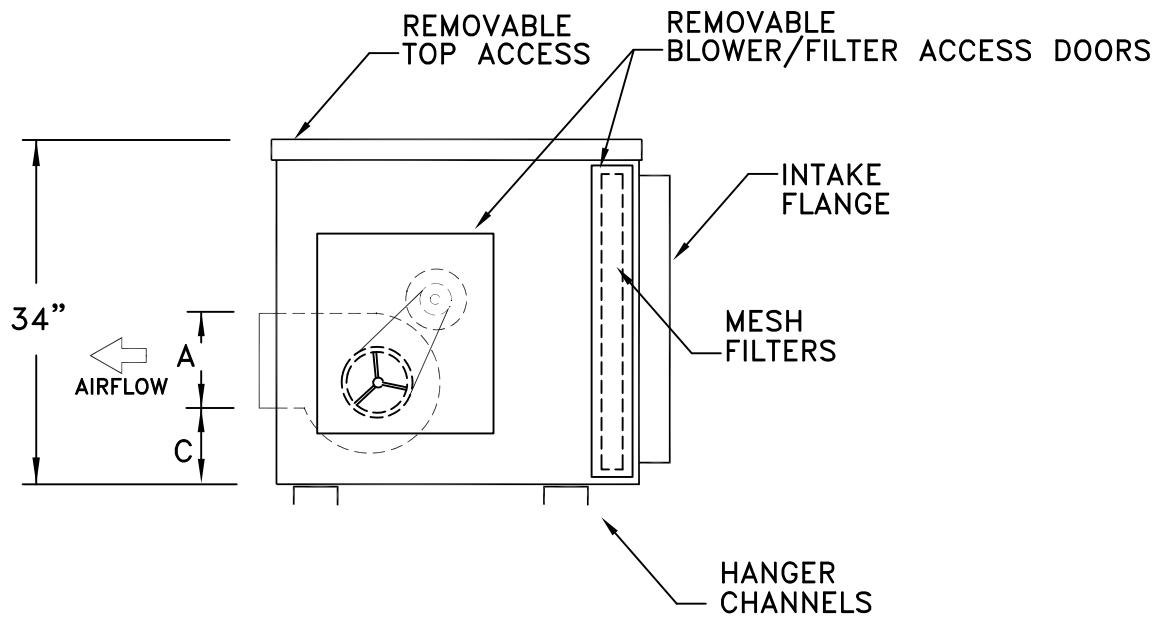

SECTION VIEW

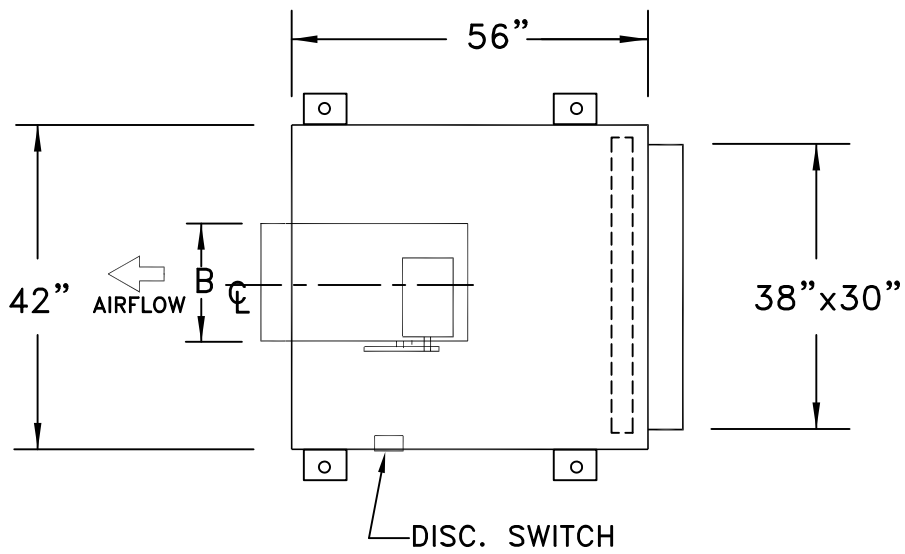

PLAN VIEW

SAS18-I

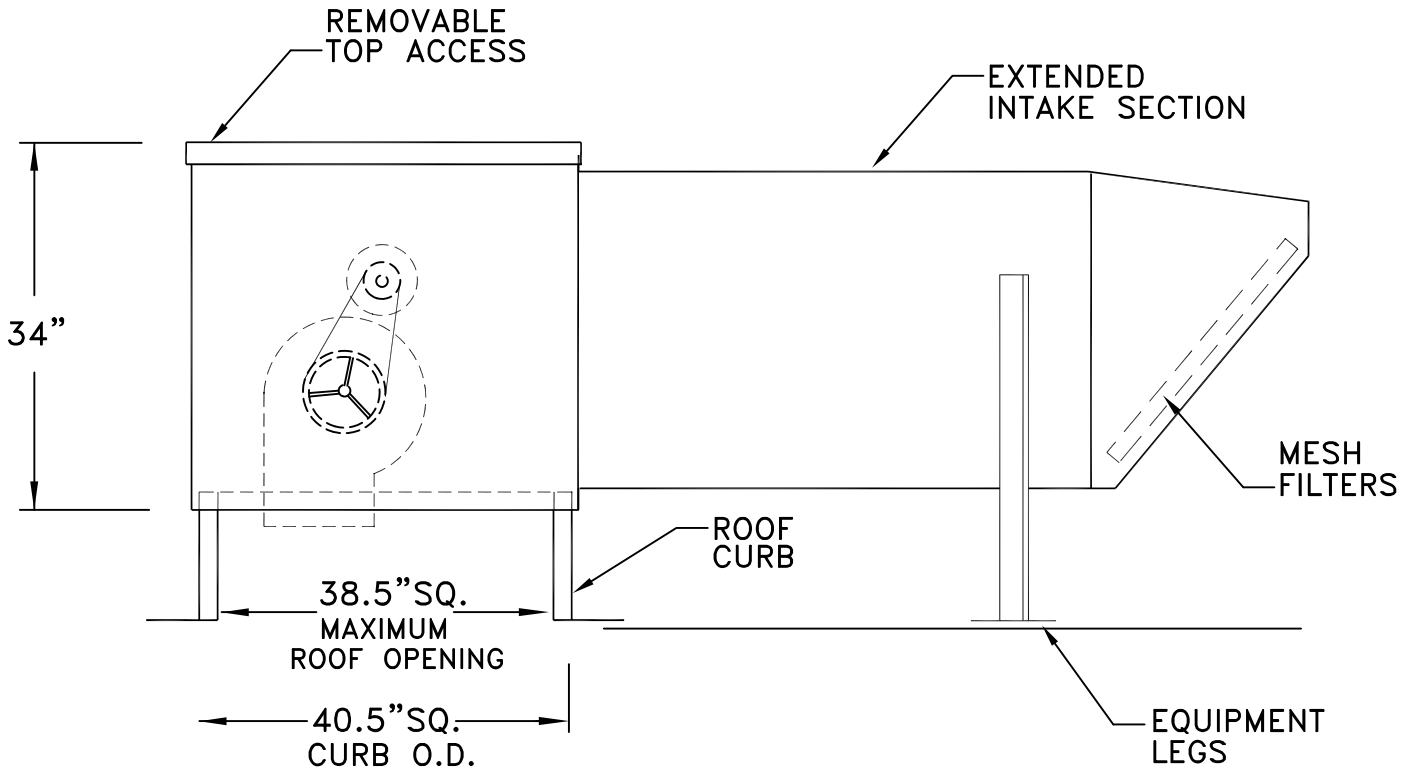

SECTION VIEW

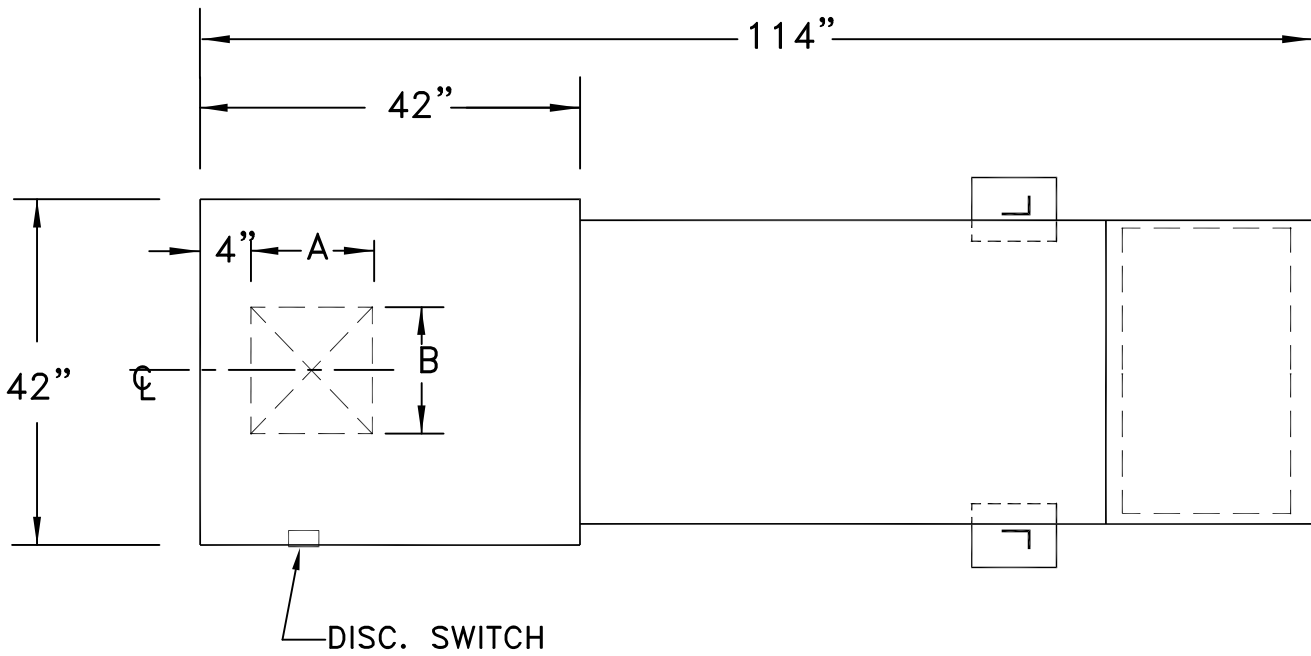

PLAN VIEW

SAS18-T